



Low Temperature & Cryogenic

STORAGE SOLUTIONS

www.cbi.com





Industry Leader

CB&I has the most extensive global experience of any tank construction company in the industry, offering liquefied gas storage solutions for almost 70 years. We have designed and built over 1,000 refrigerated storage tanks, 3,500 spheres, and more than 150 turnkey design-build liquefied gas storage terminals around the globe.

Our low temperature tanks store products at temperatures as low as -60°F (-51°C), and our cryogenic systems store liquids as low as -452°F (-268°C). We provide low temperature and cryogenic storage tanks for the entire range of liquefied gases.

Innovation

Innovation has been a cornerstone of our success for more than 125 years. Our expertise helped create the refrigerated storage industry, and our culture of innovation continues to permeate everything we do.

- 1950's** Pioneered the concept of air raising tank roofs
- 1958** Designed and built the world first double-wall Liquefied Natural Gas (LNG) storage tank
- 1958** Invented the annular space resilient insulation blanket
- 1960** Designed and built the first low temperature, double-wall tank for anhydrous ammonia storage
- 1965** Pioneered the use of cellular glass insulation as a load bearing bottom insulation
- 1965** Introduced our patented single-wall insulation system – Horizontal Foamed-In-Place (HFIP) application method
- 1966** Invented the suspended deck roof insulation system

- 1986** Designed and built the world's first full containment LNG tanks
- 2001** Pioneered the use of semi-automated austenitic UT to field examine 9% nickel plate steel weldments
- 2002** Set the record for the largest air raised roof at 89.0m (292 ft)
- 2017** Designed and built the world's largest tanks for liquid nitrogen (LIN) and liquid oxygen (LOX)

We are deeply committed to maintaining industry codes and standards, with leadership positions in American Petroleum Institute (API), American Concrete Institute (ACI), National Fire Protection Association (NFPA), and the American Society of Mechanical Engineers (ASME).

Proven Value and Capabilities

Ensuring the health and safety of our employees, customers and the community is one of our core values. CB&I upholds this value in the same way it ensures the quality of our work—implementing rigorous controls through every phase of our projects. We are firmly committed to operating all of our facilities and projects in a safe, efficient manner and in compliance with applicable safety, health, and environmental laws, rules, and regulations.

We provide single-source design and construction capabilities for low temperature and cryogenic storage projects and offers the following services:

Concept definition

- Plant siting and process hazard analysis (PHA)
- Design and detailed engineering
- Specification and procurement
- Shop fabrication



- Field construction
- Project management
- Inspection and testing
- Commissioning, start-up, and operator training

Our projects range from individual tanks and pressure spheres, to entire storage terminals including:

- Pipelines
- Boil-off compressors
- Refrigeration
- Vaporization
- Pumping and heating systems
- Rail sides
- Ship/truck loading and unloading facilities
- Fire protection systems

We provide industry-leading expertise in welding, construction, and insulation technology. Our Welding Technology group applies the latest materials and welding innovations to our projects using a full-service welding laboratory. CB&I's Construction and Fabrication Technology group applies the latest material handling and construction methods, all with a strong focus on safety and personnel training. Our Insulation Technology group assures we provide the best insulation materials, technology, and equipment available in the industry. CB&I's self-perform EPFC business model translates into a simplified client interface that reduces the complexity

and total cost of the project. This approach reduces project schedules, minimizes the customer's risk, and maintains rigorous quality control through every step of the project. We provide single-point responsibility, so our customers don't have to worry about the delays, inefficiencies, and duplication of effort that can occur when multiple contractors are involved.

	Fahrenheit (F)	Celsius (C)
Steam Point	212.0°	100.0°
Ice Point	32.0°	0.0°
1.3 Butadiene	24.1°	- 4.4°
i-Butane	10.9°	- 11.7°
Ammonia	- 28.0°	- 33.3°
Propane	- 43.7°	- 42.1°
Propylene	- 53.9°	- 47.7°
Ethane	- 128.2°	- 89.0°
Ethylene	- 154.7°	- 103.7°
Methane	- 258.7°	- 161.5°
Oxygen	- 297.3°	- 182.9°
Argon	- 302.5°	- 185.8°
Nitrogen	- 320.4°	- 195.8°
Hydrogen	- 423.2°	- 252.9°
Helium	- 452.1°	- 268.9°
Absolute Zero	- 459.7°	- 273.2°

Atmospheric Boiling Points of Low Temperature and Cryogenic Products

Low Temperature and Cryogenic Storage

We draw upon our extensive knowledge of steel plate structure design, fabrication, and welding technology, combined with knowledge of heat transfer and insulation technology to provide customers with the best integrated solution for their project. Refrigerated flat bottom storage tanks or pressurized spheres, and their accompanying insulation systems, must work together to ensure optimum performance in meeting the client's needs.

Refrigerated Flat Bottom Storage Tanks

Flat bottom tanks are designed for liquid storage operating at low pressure. Tank walls are cylindrical, roofs are typically spherical domes, and bottoms are normally flat or slightly cone shaped. We provide tanks in several types of shell and insulation configurations.

- **Single-wall single containment steel tanks** – This configuration is typically used to store low temperature products. Our single-wall tank is insulated with rigid polyurethane foam and covered with an aluminum jacket. This system offers outstanding resistance to severe weather and has an excellent vapor barrier protecting the insulation, thus lowering operating costs.
- **Double-wall single containment steel tanks** – This configuration is used for storage of low temperature and cryogenic liquids. The design features a primary liquid containment open-top inner tank and a carbon

steel primary vapor containing outer tank. As an alternative to an open top inner tank, a roof can be provided on the inner tank. Eliminating product vapor condensation in the annular space may be beneficial for storing some products.

- **Double-wall full containment steel tanks** – This configuration has an open-top steel inner tank serving as a primary liquid container and a steel outer tank suitable for the product temperature. The outer tank serves as a primary vapor containment as well as secondary liquid containment. In the unlikely event of a leak, the outer tank contains the liquid and provides controlled release of the vapor. This tank configuration reduces land requirements and provides better control of an accidental vapor release.
- **Composite steel and concrete full containment tanks** – This configuration typically has a primary liquid containment open top inner tank and a concrete outer tank. The outer tank serves as the primary vapor containment during normal operation and secondary liquid containment. In the unlikely event of a leak, the outer tank contains the liquid and provides controlled release of the vapor. The inside of the concrete wall is lined with either a steel wallpaper or our patented Free Standing Liner system. This tank configuration also reduces land requirements and provides additional resistance to external loads.

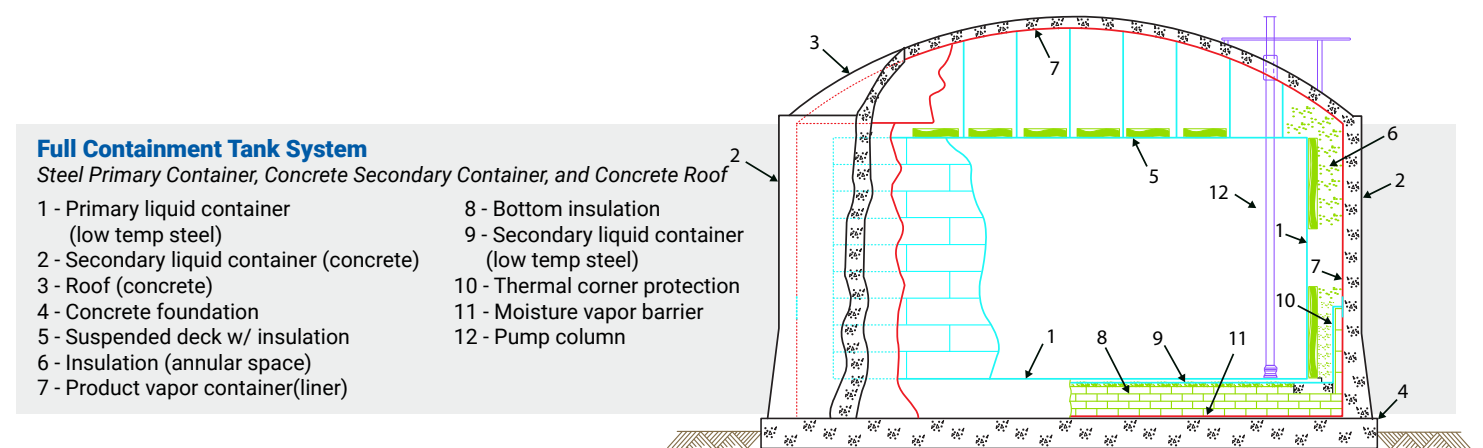
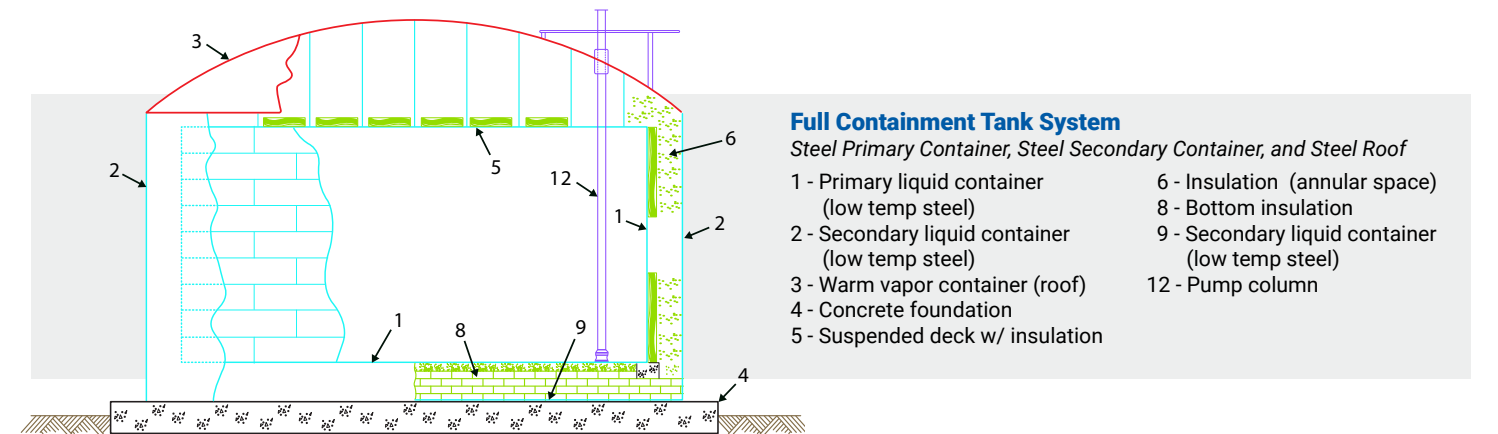
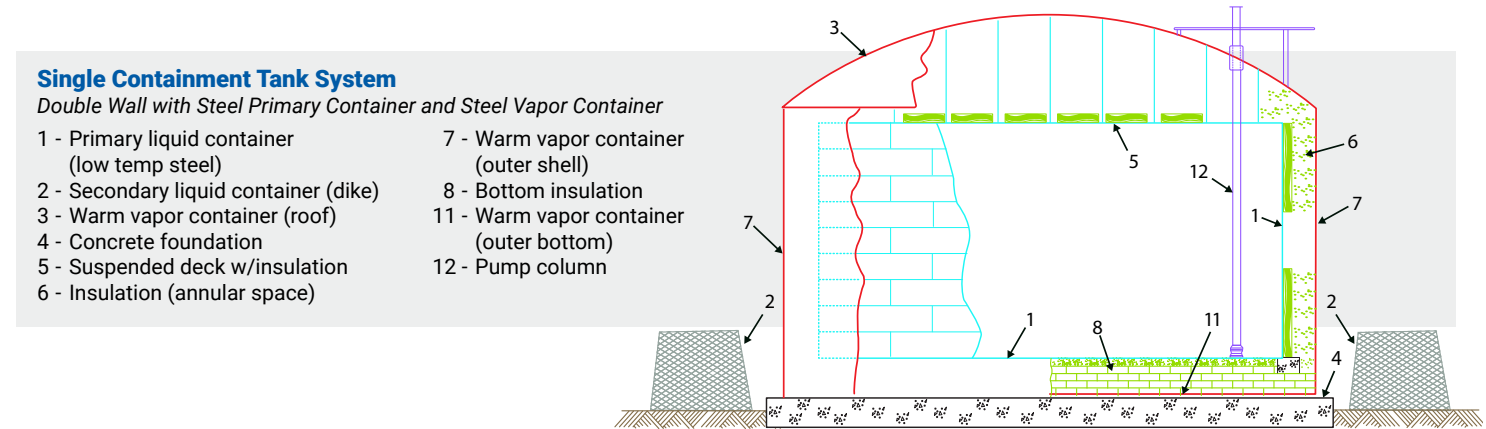
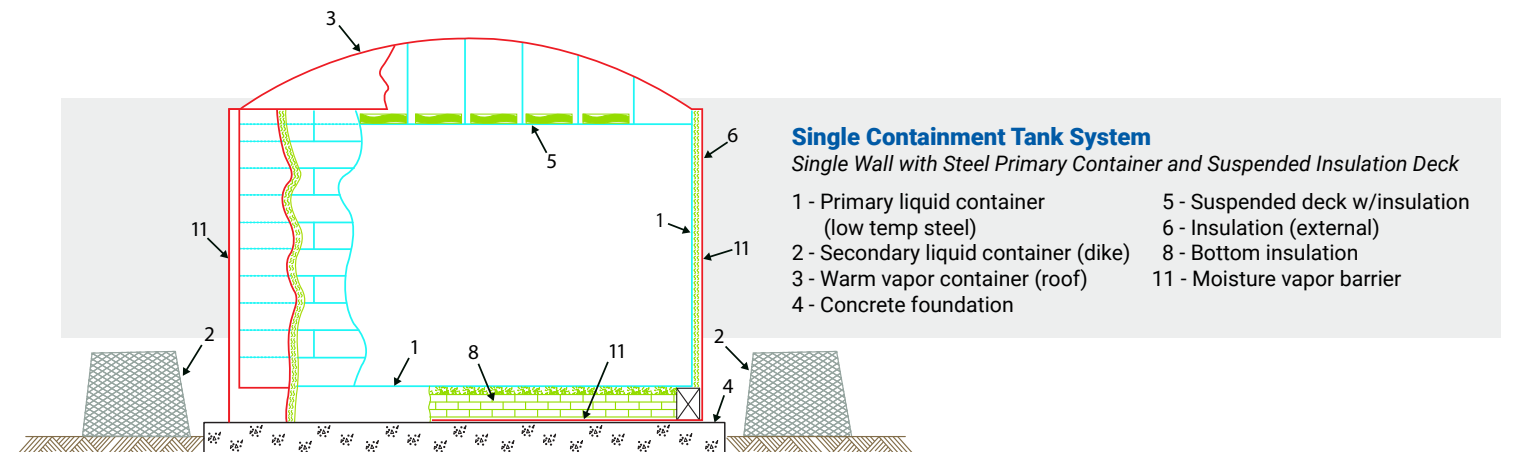

Hortonsphere® Pressure Spheres

Pressure spheres store large volumes of liquids and gases economically and reliably under a wide range of pressure and temperature conditions. Their spherical shape offers uniform stress resistance, allowing the vessels to economically contain internal pressures. Pressure spheres require less land area, yet provide more capacity than other pressure storage vessels, resulting in lower associated costs for piping, foundations, accessories, and painting. Liquefied gases can be stored in pressure spheres in a partially or fully refrigerated state, thus lowering the vessel design pressure.

Fully refrigerated Hortonsphere® vessels designed for cryogenic storage can be used to store products such as hydrogen, oxygen, nitrogen, argon, and LNG. These spheres feature double walls with an evacuated, perlite-filled annular space.



Foundation Considerations

Foundations for low temperature and cryogenic storage tanks are designed using established rules and standards, but also to prevent freezing and possible heaving of the soil. A foundation heating system can be provided just below the outer tank bottom. Or alternatively, an elevated pile cap foundation can be provided, allowing air circulation between the soil and the elevated pile cap.

Two critical factors in both the tank and foundation design are the site's soil and seismic conditions. As such, CB&I design engineers work with customers to coordinate an early and comprehensive geotechnical investigation, which reduces the potential for costly design adjustments later in the project.

Insulation System Considerations

Low temperature and cryogenic storage vessels (both tanks and spheres) and their insulation materials must be designed as a system to ensure optimum performance.

Load Bearing Insulation

All flat bottom refrigerated and cryogenic storage tanks require bottom insulation to limit the heat flux into the stored product and transmit the liquid load into the foundation. Cellular glass blocks are typically used for this application.

Single-Wall Insulation

Having successfully completed over 165 installations, our patented single-wall Horizontal Foamed-In-Place (HFIP™) insulation system consists of rigid polyurethane insulation foamed-in-place between the steel tank shell and an aluminum jacket. This results in a monolithic insulation, without cracks or voids, fully bonded in a "sandwich" construction between the tank shell and the outer jacket. The outer jacket serves as both the moisture vapor barrier and weather protection for the system. Vertical standing seam panel insulation systems can be provided if desired.

Double-Wall Insulation

Our double wall insulation system is designed to last for the life of welded steel structures. All insulation is protected from the elements, ensuring trouble-free, consistent performance. Sidewall insulation is provided by expanded perlite and resilient blanket installed against the inner tank shell. The outer wall provides both vapor containment and protection for the perlite insulation.

Suspended Deck Roof Insulation

Common to both single-wall and double-wall tank configurations, our suspended deck insulation system consists of a metal deck suspended from the tank roof framing. Perlite, mineral wool, glass fiber, or other suitable insulation is distributed uniformly over the suspended deck. The tank roof provides permanent weather protection for the suspended insulation.



Terminals, Facilities and Systems

CB&I provides complete engineering, procurement, fabrication, and construction services for the following scopes of work:

- Storage vessels, complete with foundations and insulation
- Refrigeration and liquefaction systems
- Unloading and loadout equipment, including marine topsides
- Product heaters and vaporizers
- Rail, truck, and marine loading/unloading
- Roads, dikes, and miscellaneous civil works
- Mechanical, electrical, control, and instrumentation systems
- Fire hazard detection, protection, and safety systems
- Buildings and enclosures

Refrigeration and Liquefaction Systems

We specialize in the design of low temperature and cryogenic processes associated with refrigerated storage, including the process to chill the incoming product to conditions required for storage and to convert the liquid back to a vapor. We can design and supply refrigeration systems to chill liquid products or liquefaction processes to liquefy gases, including the necessary metering, pretreatment, boil-off, and BTU reduction subsystems.

Send-out System

We have extensive experience in the design and installation of pump-out and product heating/vaporizing systems that provide reliable service throughout the life of the facility. Pump out systems may include external pumps, generally installed in deep wells adjacent to the tank, or in-tank pumps, submersed within pump tubes in the tank.

Control and Instrumentation

All refrigerated and cryogenic facilities require an integrated control, instrumentation, and electrical system. We can provide reliable local and/or remote control systems that permit automatic facility operation, safe shutdown, and if desired, unattended operation.

Buildings and Civil Works

We provide complete design and construction of all buildings and civil work associated with low temperature and cryogenic facilities. This includes buildings or shelters to house compressors and auxiliary mechanical equipment, control facilities, and utilities as required for a complete operating facility.

Fire Protection

Fire protection is a basic consideration for all low temperature and cryogenic facilities. We have furnished complete fire protection systems of varying complexity, including closed-loop water systems, wet or dry spray systems, foam systems, dry chemical extinguishers, and other types of fire protection systems.

CB&I is the world's leading designer and builder of storage facilities, tanks, and terminals. With more than 60,000 structures completed throughout its 135+ year history, CB&I has the global expertise and strategically located operations to provide its customers world-class storage solutions for even the most complex energy infrastructure projects. CB&I is owned by a consortium of financial investors led by Mason Capital Management. To learn more, visit www.cbi.com.

Headquarters

1725 Hughes Landing Blvd, Suite 600
The Woodlands, TX 77380
USA
Tel: +1 832-513-4000
www.cbi.com

